

# Worm bin construction

## Wood worm bin

This wood worm bin is used mostly for fruit and vegetable trimmings. The bin may require occasional watering. The bin also doubles as a seat. Basic carpentry skills are needed for construction. Budget \$30 to \$50 for new materials, or better yet, use salvaged materials.

### MATERIALS

- 4' x 4' piece  $\frac{1}{2}$ " exterior grade non-treated plywood (1)
- 2 x 2" wood: 6' (3)
- 2 x 4" wood: 4' (1)
- 4 penny galvanized nails (1 lb.)
- Light cable or chain: 16"
- $\frac{1}{2}$ " wood screws (2)
- 2" hinges (2), with  $\frac{3}{4}$ " wood screws (2)
- Solvent-free, low VOC, waterproof wood glue

### TOOLS

Power saw or hand saw, hammer, measuring tape, pencil, square, drill with  $\frac{1}{4}$ " and  $\frac{3}{32}$ " bits, sandpaper.

Use proper eye, ear and body protection.

### ASSEMBLY

Glue all wood pieces before nailing.

#### Base

Nail two 23" 2 x 4s and two 19  $\frac{7}{8}$ " 2 x 2s to bottom of 23 x 23" plywood as drawn. Drill at least twenty-four  $\frac{1}{4}$ " holes for drainage.

#### Side

Front and back walls: Nail the four 2 x 2 uprights to the two side walls along the 11  $\frac{3}{4}$ " edge, with one end of each 2 x 2 flush with the top edge of the walls. Nail a 19  $\frac{7}{8}$ " 2 x 2 hinge support to the top edge of the back wall piece, leaving 1  $\frac{1}{2}$ " on each side for 2 x 2 uprights. Assemble box by nailing the 1  $\frac{1}{4}$ " overhang of the side walls to the 2 x 2s on the base as drawn. Nail the front and back walls to the 2 x 2 uprights and to the 2 x 4s on the base as drawn. Be sure the hinge support is at the top of the bin.

#### Lid

Nail lid together as drawn. Attach to box with hinges, making sure to pre-drill screw holes into the 2 x 2s and position hinges as drawn. Attach chain with  $\frac{1}{2}$ " wood screws so lid can rest in an opened position.

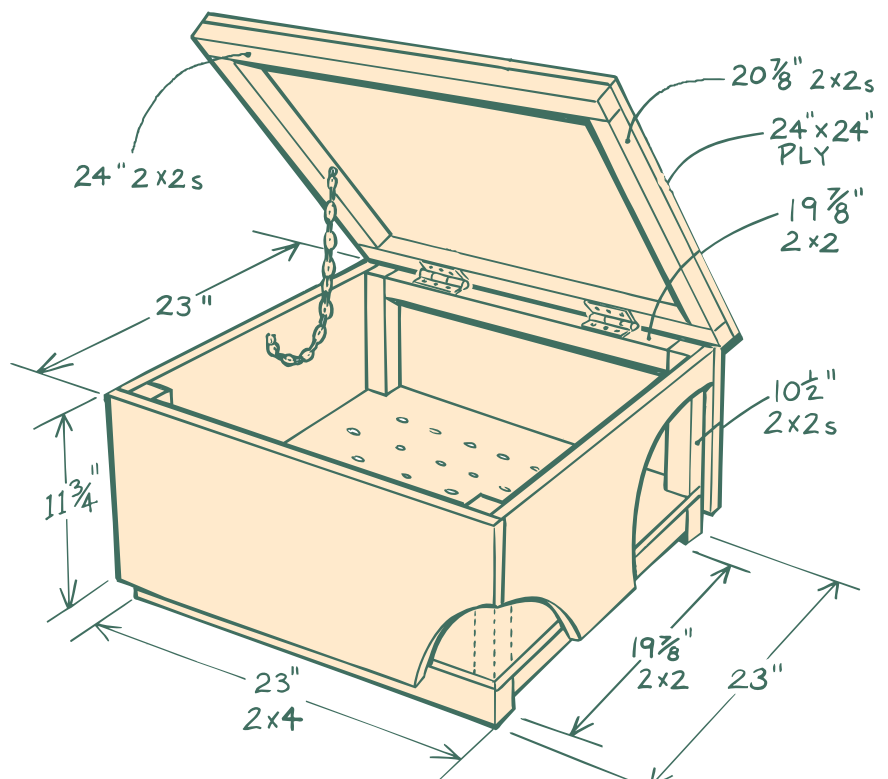

# Worm bin construction

## Plastic worm bin

This bin is used mainly for fruit and vegetable trimmings. It is very easy to build and tidy for indoor use. The plastic bins keep compost moist and will require regular additions of dry bedding. Budget \$6 to \$20 for new materials, or better yet, use salvaged materials.

### MATERIALS

Plastic storage container with a tight fitting lid measuring 12" to 18" tall; 12" x 24" base.

### TOOLS

Power drill with 1/4" bit

### ASSEMBLY

#### For outdoor use

Drill at least 6 holes per side for ventilation about one-half to three quarters of the way up the sides of the bin. Drill at least 12 holes in the bottom of the bin for drainage.

#### For indoor use

Drill at least 6 holes per side for ventilation about one-half to three quarters of the way up the sides of the bin. To avoid a future mess from moisture dripping out the bottom of the worm bin, you can either forgo drainage holes, or drill drainage holes and use a second plastic storage bin as a catchment tray. If you forgo the drainage holes, be sure to monitor moisture levels and prevent puddling. When moisture content is high, add dry bedding under and on top of the food and worms to absorb excess moisture.



Metro